

HEAT WAVE DUCT KIT

KIT # 946-568



**Approved for use with Models:
P36, P36D, P42, P48, P90, P95, L676S, P33S & HZ54**

WARNING:

Improper installation, adjustment, alteration, service or maintenance can cause injury or property damage. Refer to this manual. For assistance or additional information consult an authorized installer, service agency or the gas supplier.

FOR YOUR SAFETY

Do not store or use gasoline or other flammable vapours and liquids in the vicinity of this or any other appliance.

Installation and service must be performed by an authorized installer, service agency or the gas supplier.

FOR YOUR SAFETY

What to do if you smell gas:

- * Do not try to light any appliance
- * Do not touch any electrical switch: do not use any phone in your building.
- * Immediately call your gas supplier from a neighbour's phone. Follow the gas supplier's instructions.
- * If you cannot reach your gas supplier, call the fire department.

**PLEASE KEEP THESE INSTRUCTIONS
FOR FUTURE REFERENCE**

Tested by: Warnock Hersey



Manufactured by:
FPI Fireplace Products International Ltd.
6988 Venture St.,
Delta, B.C. Canada, V4G 1H4



LISTINGS AND CODE APPROVALS

This Kit has been approved for use with Model P36, P36D, P42, P48, P90, P95, L676S, P33S & HZ54. This kit has been tested in accordance with National Safety Standards, and has been certified by Warnock Hersey for installation and operation in the United States and Canada as described in these Installation and Operating Instructions.

Check with your local building code agency before you begin your installation to ensure compliance with local codes, including the need for "permits" and follow-up inspections. If any problems are encountered regarding code approvals, or if you wish clarification on any of the instructions contained here, contact your local dealer.

GENERAL INFORMATION

The Heat Wave Air Duct Kit increases the effectiveness of your fireplace by dispersing warm air from the fireplace to remote locations in the same room or other rooms in your home.

Up to two kits may be installed on the fireplace. **Please Note:** Only 1 HeatWave kit may be operated at one time. This includes the internal blower option as well.

IMPORTANT INSTALLATION NOTES

- 1) The appliance installation must conform with local codes or, in the absence of local codes, with the current Canadian or National Gas Codes, CAN1-B149 or ANSI Z223.1 Installation Codes.
- 2) The appliance when installed, must be electrically grounded in accordance with local codes, or in the absence of local codes with the current National Electrical Code, ANSI/NFPA 70 or CSA C22.1 Canadian Electrical Code.

- 3) This kit is tested and safe when installed in accordance with this installation manual. Please read all instructions before starting installation and follow all instructions carefully during installation.
- 4) Installation of this kit must be performed by a qualified service technician.
- 5) The Heat Wave Kit must be installed only as specified. Any modifications of the kit or components will void the warranty and may cause a fire hazard.
- 6) Plan the location of the fireplace and the warm air duct runs, see diagram 1 as a guide for possible duct runs and locations.

Maximum Duct Run: 20 ft. (6.1m) per kit.

NOTE: Airflow through the duct system is affected by the duct length and number of bends. Keep the length and bends to a minimum to maximize performance.

PARTS

Included with Kit:

- 1 946-010 20 ft. (6.1 m) of 6" dia. flex pipe
 - 1 946-517 Fan housing assembly
 - 1 910-423 Variable wall rheostat
 - 1 946-006 Air register
 - 1 946-005 Register adaptor frame (thick)
 - 1 946-000 Round Duct collar
 - 1 946-001 Oval Duct collar
 - 1 946-002 Duct adaptor (round to oval)
 - 1 946-045 Insulation (60")
- Hardware package

If any parts are missing or damaged, contact your dealer before starting installation. DO NOT install a damaged kit.

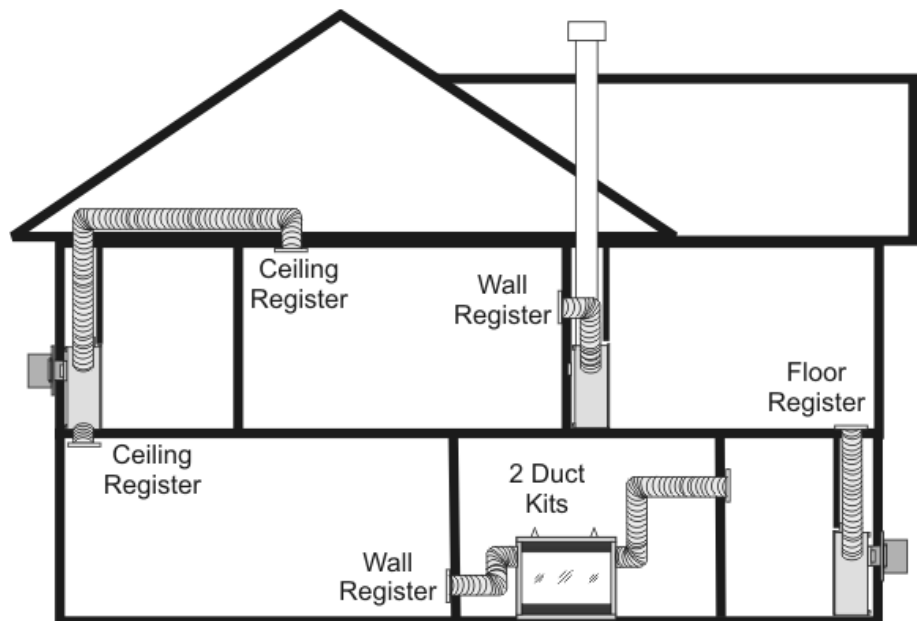
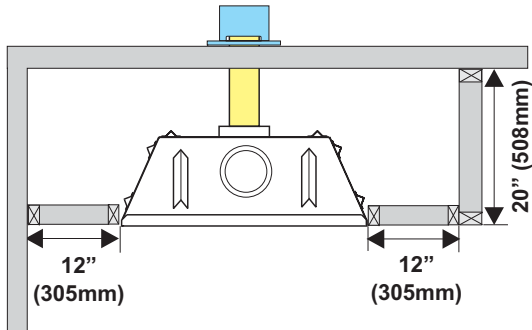

Diagram 1: Guide for possible air duct runs and locations. Keep duct length and number of bends to a minimum. Maximum duct length is 20 ft. (6.1m) per kit.

MINIMUM FRAMING CLEARANCES

- * Wall studs must be 16" on center for mounting fan housing.
- * Fan Housing: Maintain a 1/4" (6mm) clearance from fan housing to combustible material.
- * Wall Registers must be 4" (102mm) from floor above or ceiling below.

P33 / P36 / P36D / P48



P48

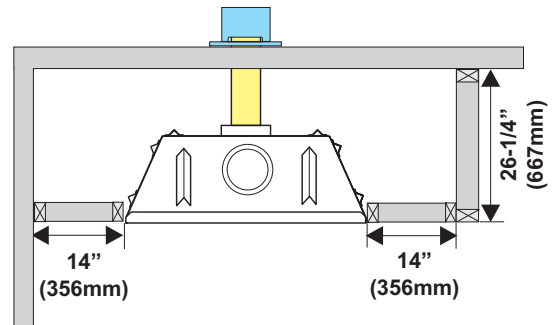

P90 / P95 - Top Exit

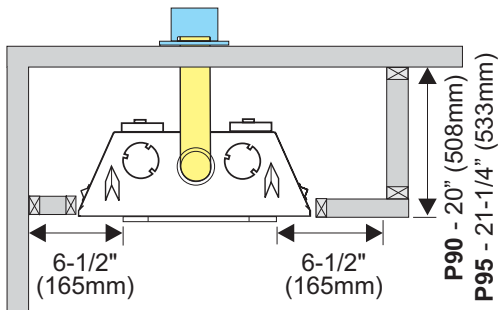

P90 / P95 / HZ54 - Side Exit

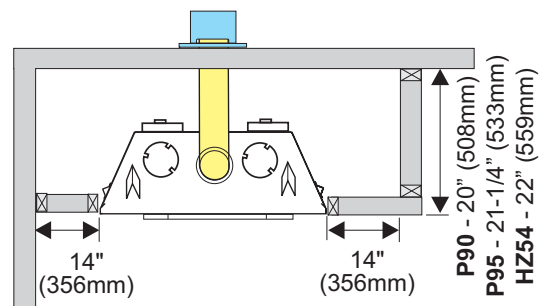

Minimum Duct Clearances

The air duct has a '0' clearance to combustibles but the first 24" of pipe from the unit requires insulation (included with kit). See diagram 4 on page 3.

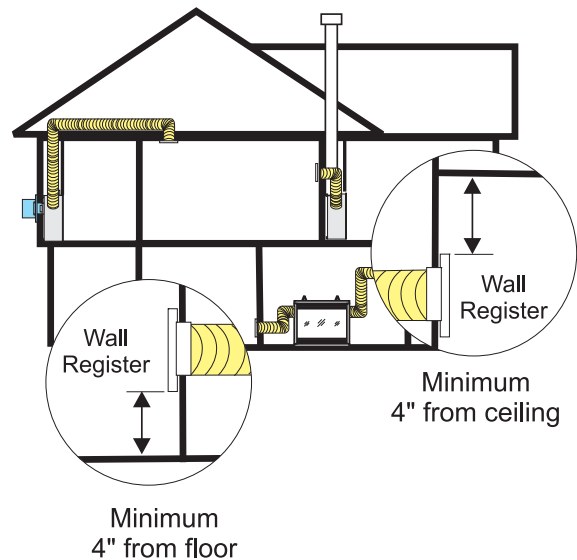

INSTALLATION

NOTE: Installation of Heat Wave duct kit should be done prior to drywall installation.

A) P36, P36D, P42, P48, P90, P95 & HZ54 models:

- 1) Remove the cover plate from the fireplace side and discard.



Remove the 2 screws holding the cover plate on the fireplace side.

- 2) Remove the knock-out and bend the tabs outward.

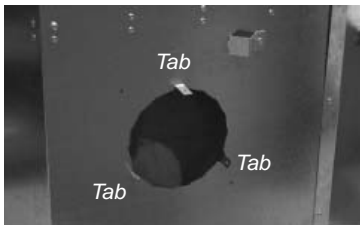

Center Round Duct collar over hole and attach to the tabs using 3 screws

A) P90 / P95 Model:

- 1) Remove the knockout plate from the fireplace top and discard.

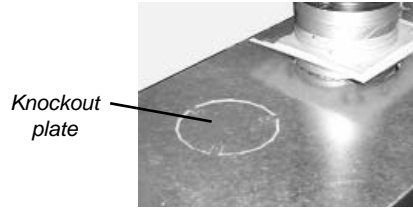

- 2) Bend the tabs outward.

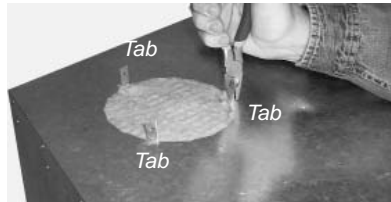

- 3) Cut out and remove the insulation under the top opening.



- 4) Push Round Duct Collar through to inner shell top and attach to all 3 tabs on fireplace top with screws.



Round Duct Collar pushed down to inner shell

B) All models:

- 1) Determine the location of the air register/fan housing assembly. Cut a 5" x 16" (121mm x 406mm) hole between framing members (wall studs or floor joists). Maintain a 1/4" (6mm) clearance from fan housing to combustible material. See page 2 for clearances.
- 2) Mount and secure the fan housing assembly to framing members, the front of the fan housing will protrude 1/2" (51mm) out of the wall so it may be finished with drywall, etc. See diagram 2.

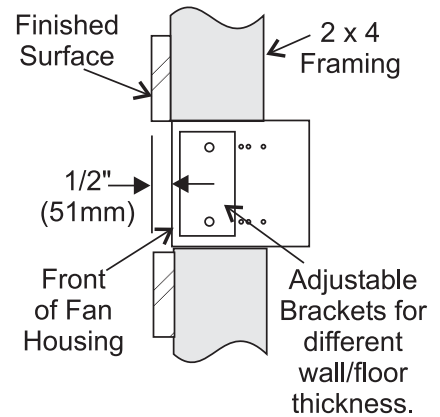
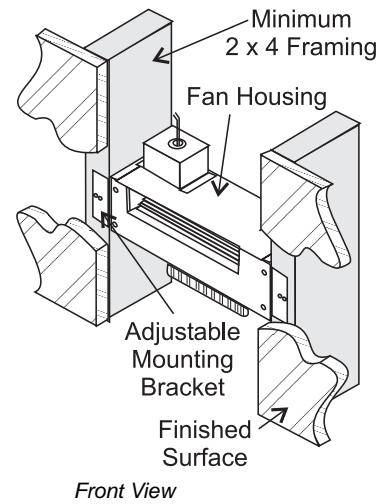

Diagram 2 Side View: Secure fan housing to minimum 2 x 4 framing.

NOTE: This must be done prior to placing fireplace into final position.

- 3) Install the air duct run. The air duct run has a zero clearance to combustibles construction but the first 24" of the pipe from the unit requires insulation (included with kit). Check local codes.

Secure the duct to the duct collar on the unit and to the fan housing with 3 screws (per end) and aluminum duct tape (UL 181A-P or equivalent).

The first 24" of duct pipe (from the unit) must be covered with insulation.

Round Air Duct: Attach the 6" round air duct (supplied) to the fireplace collar and run the duct to the fan housing. Attach the round-to-oval adaptor to the fan housing and the air duct to the adaptor, diagram 3.

Oval Air Duct: Attach the round-to-oval adaptor to the fireplace starting collar and a 6" oval duct (not supplied) to the adaptor. Complete the duct run and attach the oval duct to the fan housing.

Round and Oval Duct: A combination of 6" round and 6" oval duct can be used in the duct run. Oval duct components are not supplied but can be purchased from an HVAC supplier.

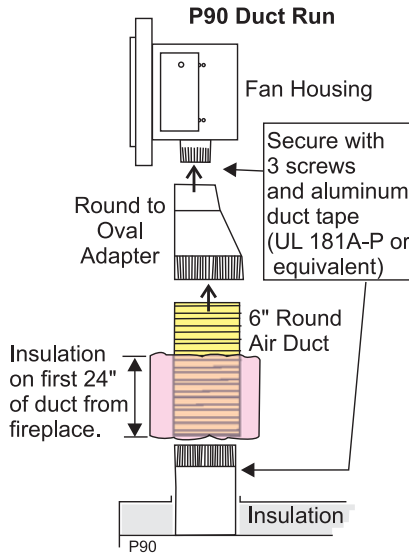

Diagram 3: P90 model

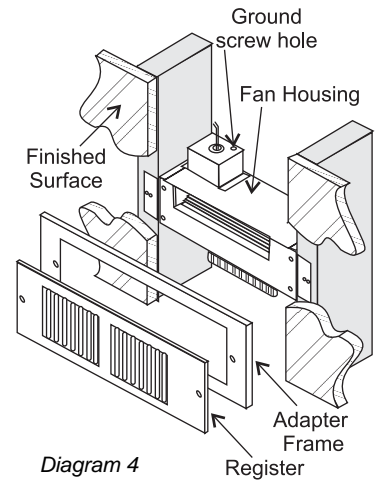

Diagram 4

- 8) Complete the fireplace installation as per fireplace installation manual.

- 4) Install the variable speed Wall Rheostat (with OFF setting) in a convenient location. This switch controls the fan operation.
- 5) Wire 120V AC service to the Wall Rheostat and from the Wall Rheostat to the Fan Junction Box. Use wire nuts to secure the 120V AC wires to the hot and neutral fan wires and screw the 120V AC ground wire to the Fan Junction Box. See wiring diagram below.
- 6) Screw the fan junction box to the fan housing.
- 7) Screw the Register Adapter Frame and the Air Register to the Fan Housing, diagram 4.

Note: For new construction only the Air Register is required to cover the opening.

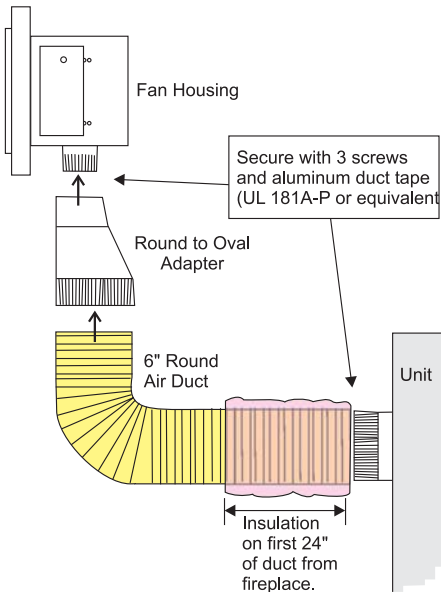
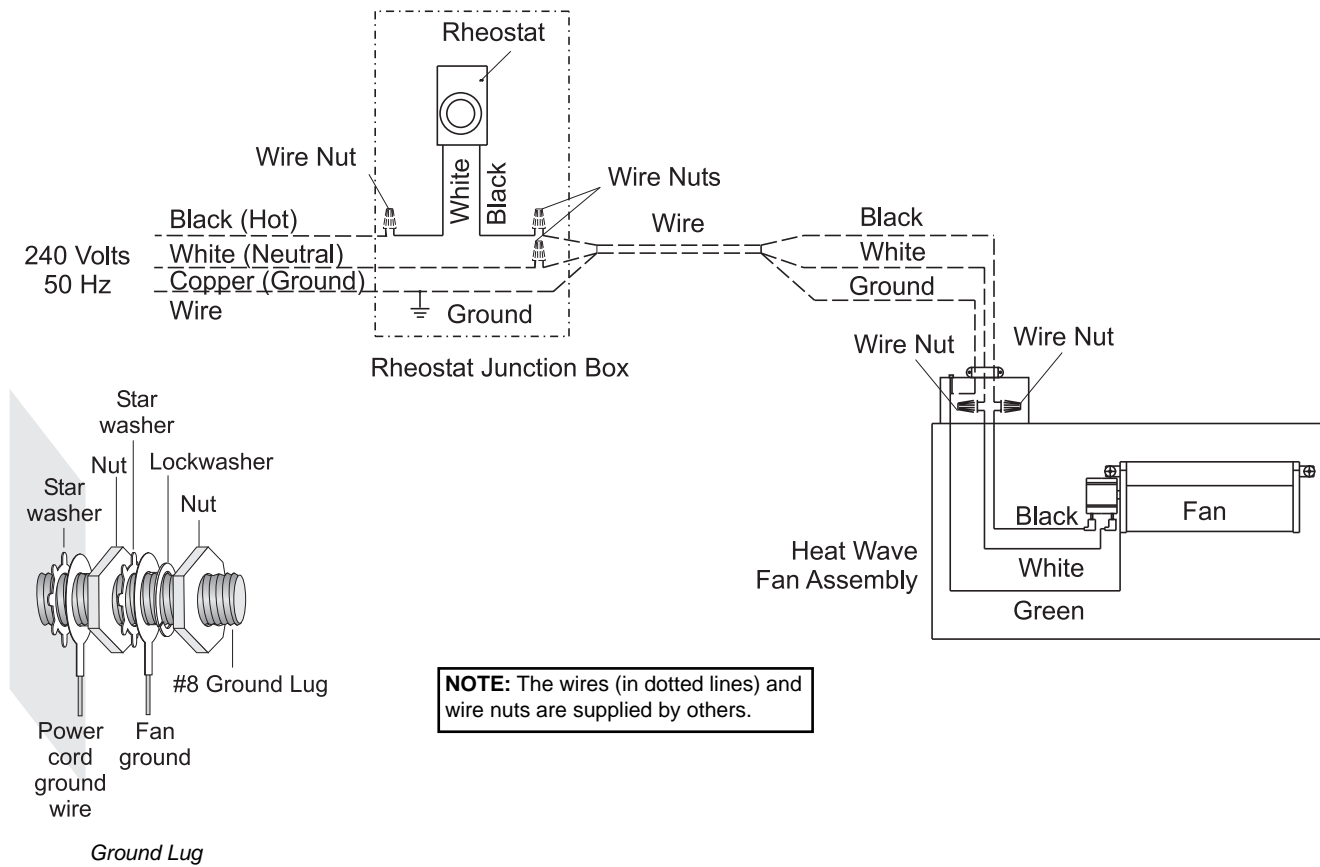

Diagram 3: P36, P36D, P42 & P48 models

WIRING DIAGRAM



Caution: Ensure that the wires do not touch any hot surfaces and are away from sharp edges.

Do not cut the ground terminal off under any circumstances.

CAUTION: Label all wires prior to disconnection when servicing controls. Wiring errors can cause improper and dangerous operation.

IMPORTANT: If the internal blower is installed, it cannot be operated if the Heat Wave air duct kit fan is operating.

OPERATION

- 1) Start the fireplace as per instructions and allow it to warm up.
- 2) Turn the Wall Rheostat "ON" and adjust the variable speed based upon desired air flow at the Air Duct Register.

MAINTENANCE

- 1) Service and maintain the fireplace as per the fireplace installation manual.
- 2) Keep the Air Register(s) clean and free of any blockage.

